



Electrak® LA14 – Technical Features



Standard Features

- Robust and reliable
- 12, 24 or 36 Vdc as standard input voltages
- Acme and ball screw models
- Static load up to 18 kN (4000 lbf)
- Dynamic load up to 6.8 kN (1500 lbf)
- Stroke up to 24 in
- Speed up to 61 mm/s (2.4 in/s)
- Protection class static IP65
- Overload clutch for mid and end of stroke protection
- Motor with thermal switch
- Corrosion free aluminium cover tube
- Anti-rotation mechanism
- T-slots in the cover tube for magnetic sensors
- Trunnion mounting possible
- Maintenance free

General Specifications

Screw type	acme or ball
Nut type Dxx-xxA (acme screw) Dxx-xxB (ball screw)	self-locking lead nut load lock ball nut
Manual override	no (optional)
Anti-rotation	yes
Static load holding brake acme screw models ball screw models	no (self-locking) yes
Safety features	overload clutch motor auto reset thermal switch
Electrical connections no potentiometer option with potentiometer option	flying leads with or without connector cable with or without connector
Compliances	CE

Optional Mechanical Features

Variety of front and rear adapters

Variety of rear adapter orientations

Manual override

Optional Electrical Features

Potentiometer feedback

Accessories

External slot-mounted limit switches

Mounting pin kits

Mounting pin bracket kits

Trunnions mounting kits

Compatible Controls

Contact customer support at www.thomsonlinear.com/cs

Electrak[®] LA14 – Technical Specifications

Mechanical Specifications		
Max. static load ⁽¹⁾	[N (lbf)]	
DAxx-xxA (acme screw)		11350 (2500)
DAxx-xxB (ball screw)		18000 (4000)
Max. dynamic load (Fx)	[N (lbf)]	
DAxx-05A65M		1100 (250)
DAxx-10A65M		2250 (500)
DAxx-20A65M		2250 (500)
DAxx-05B65M		2250 (500)
DAxx-10B65M		4500 (1000)
DAxx-20B65M		4500 (1000)
DAxx-21B65M		6800 (1500)
Speed @ no load/max. load	[mm/s (in/s)]	
DAxx-05A65M		54/32 (2.10/1.20)
DAxx-10A65M		30/18 (1.20/0.70)
DAxx-20A65M		15/12 (0.67/0.45)
DAxx-05B65M		61/37 (2.40/1.40)
DAxx-10B65M		30/19 (1.30/0.80)
DAxx-20B65M		15/12 0.60/0.45)
DAxx-21B65M		15/11 (0.60/0.43)
Min. ordering stroke (S) length	[mm]	50
Max. ordering stroke (S) length ⁽²⁾	[mm]	600
Ordering stroke length increments	[mm]	50
Operating temperature limits	[°C (F)]	-25 – 85 (-15 – 185)
Full load duty cycle @ 25 °C (77 °F)	[%]	25
End play, maximum	[mm (in)]	1.0 (0.04)
Restraining torque	[Nm (lbf-in)]	0
Protection class - static		IP65
Salt spray resistance	[h]	96

(1) Max. static load at fully retracted stroke

Electrical Specifications		
Available input voltages ⁽¹⁾	[Vdc]	12, 24, 36
Input voltage tolerance	[%]	± 10
Current draw @ no load/max. load ⁽²⁾	[A]	
DA12-05A65M		12.0/34.0
DA12-10A65M		9.0/27.0
DA12-20A65M		8.0/15.0
DA12-05B65M		8.0/26.0
DA12-10B65M		5.0/26.0
DA12-20B65M		4.0/14.0
DA12-21B65M		4.0/19.0
DA24-05A65M		6.0/17.0
DA24-10A65M		4.5/13.5
DA24-20A65M		4.0/7.5
DA24-05B65M		4.0/13.0
DA24-10B65M		2.5/13.0
DA24-20B65M		2.0/7.0
DA24-21B65M		2.0/9.5
Flying leads length	[mm (in)]	165 (7.5)
Flying leads diameter	[mm (in)]	3 (0.12)
Flying leads cross section	[mm ² (AWG)]	2 (14)
Cable length with option pot.	[mm (in)]	600 (24)
Cable diameter with option pot.	[mm (in)]	9 (0.35)
Cable leads cross section with option potentiometer	[mm ² (AWG)]	
motor leads		2.5 (14)
potentiometer leads		1.5 (16)

(1) For other input voltages - contact customer support

(2) For current draw for 36 Vdc input voltage models - contact customer support



Electrak® LA14 – Dimensions

Dimensions	Projection
mm [inch]	

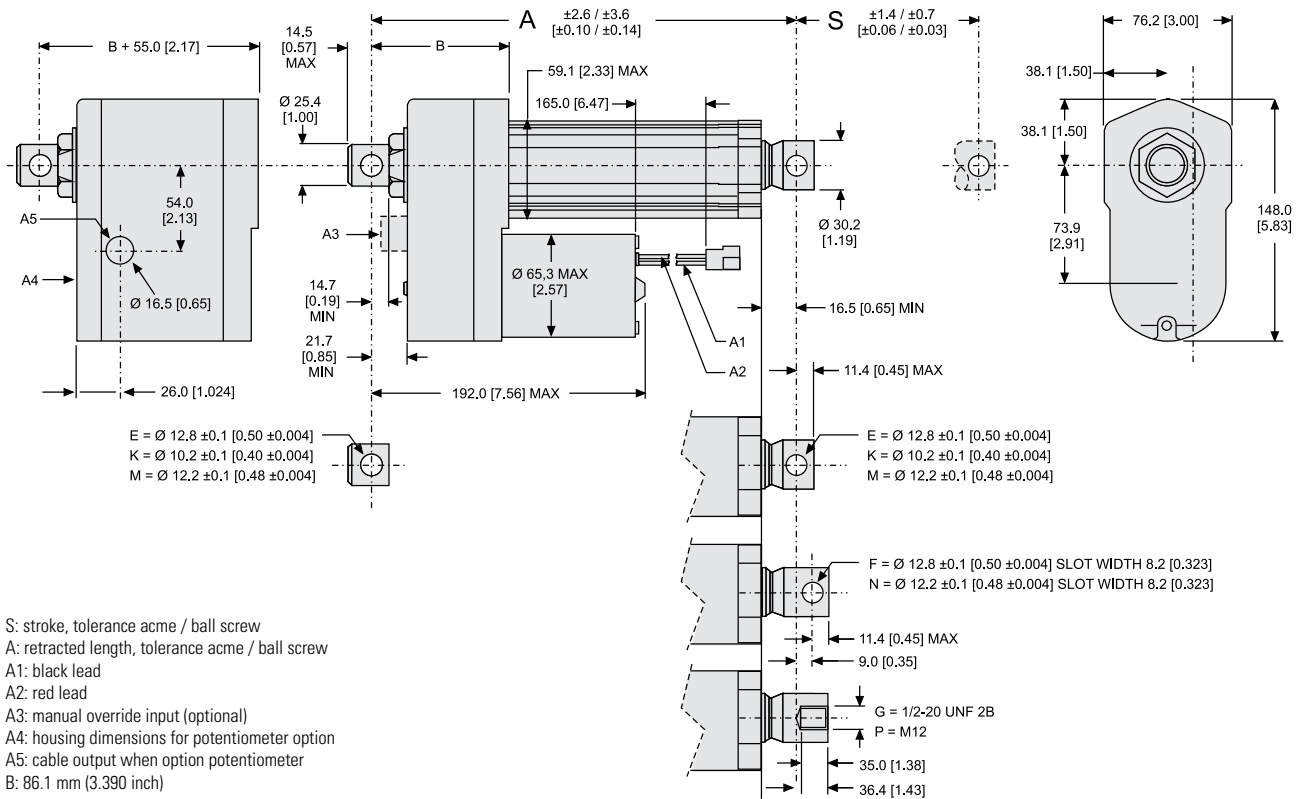

Stroke, Retracted Length and Weight Relationships

Ordering stroke (S)	[mm]	50	100	150	200	250	300	350	400	450	500	550	600
Retracted length, acme screw models (A)	[mm]	219.9	269.9	319.9	369.9	419.9	469.9	586.6	636.6	686.6	736.6	786.6	836.6
	[in]	8.86	10.62	12.59	14.56	16.53	18.50	23.09	25.06	27.03	29.00	30.97	32.94
Retracted length, ball screw models (A)	[mm]	269.6	319.6	369.6	419.6	469.6	519.6	623.4	673.4	723.5	773.4	823.4	873.4
	[in]	10.61	12.58	14.55	16.52	18.49	20.46	24.54	26.51	28.48	30.45	32.42	34.39
Add on length for option potentiometer	[mm]	55.0											
	[in]	2.17											
Weight, acme screw models	[kg]	4.5	4.7	4.9	5.1	5.3	5.5	5.8	6.0	6.2	6.4	6.6	6.8
	[lbf]	9.9	10.3	10.8	11.2	11.7	12.1	12.8	13.2	13.6	14.1	14.5	15.0
Weight, ball screw models	[kg]	5.3	5.5	5.7	5.9	6.1	6.3	6.6	6.8	7.0	7.2	7.4	7.6
	[lbf]	11.7	12.1	12.5	13.0	13.4	13.9	14.5	15.0	15.4	15.8	16.3	16.7
Add on weight for option potentiometer	[kg]	1.30											
	[lbf]	3.31											

Electrak® LA14 – Performance Diagrams

Acme Screw Models
Speed and Current vs. Load

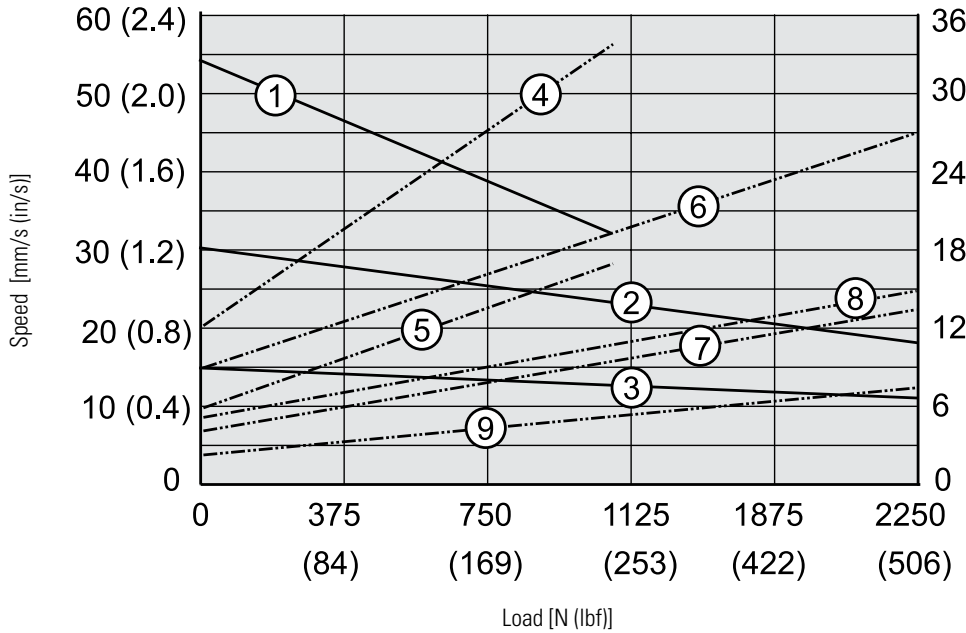

- Speed
1: DAxx-05A65M
2: DAxx-10A65M
3: DAxx-20A65M

- Current
4: DA12-05A65M
5: DA24-05A65M
6: DA12-10A65M
7: DA24-10A65M
8: DA12-20A65M
9: DA24-20A65M

Ball Screw Models
Speed and Current vs. Load

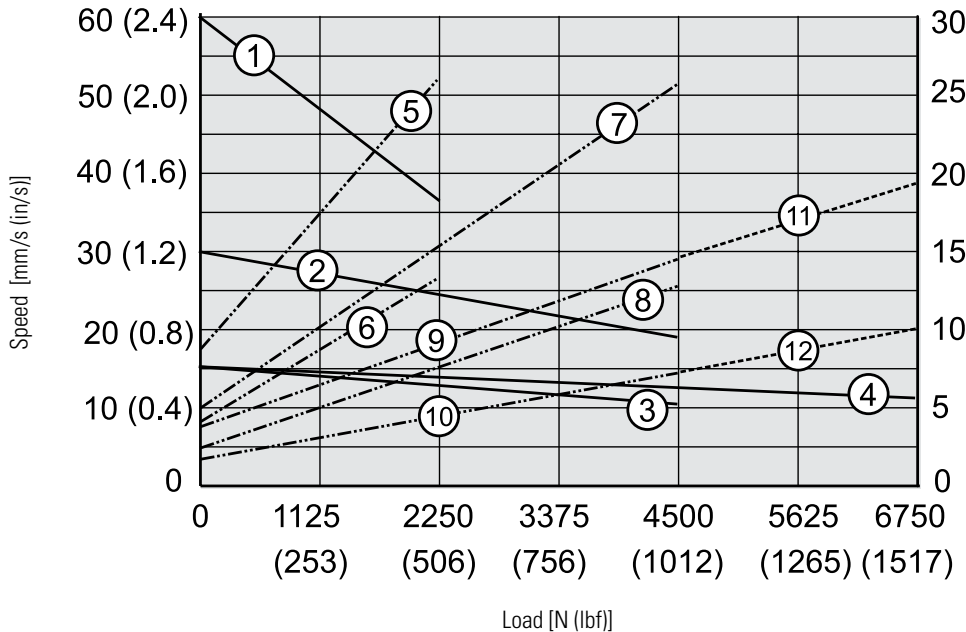

- Speed
1: DAxx-05B65M
2: DAxx-10B65M
3: DAxx-20B65M
4: DAxx-21B65M

- Current
5: DA12-05B65M
6: DA24-05B65M
7: DA12-10B65M
8: DA24-10B65M
9: DA12-20B65M
10: DA24-20B65M
11: DA12-21B65M
12: DA24-21B65M

Note: for current draw data for 36 Vdc input voltage models - contact customer support.



Electrak® LA14 – Ordering Key

Ordering Key

1	2	3	4	5	6	7	8
DA12-	05A65M	10	MO	N	-A	F	M

1. Model and input voltage

DA12- = Electrak LA14, 12 Vdc
 DA24- = Electrak LA14, 24 Vdc
 DA36- = Electrak LA14, 36 Vdc

2. Dynamic load capacity, screw type, maximum speed

05A65M = 1100 N, acme, 54 mm/s
 10A65M = 2250 N, acme, 30 mm/s
 20A65M = 2250 N, acme, 15 mm/s
 05B65M = 2250 N, ball, 61 mm/s
 10B65M = 4500 N, ball, 30 mm/s
 20B65M = 4500 N, ball, 15 mm/s
 21B65M = 6800 N, ball, 15 mm/s

3. Ordering stroke length

05 = 50 mm (1.97 in)
 10 = 100 mm (3.94 in)
 15 = 150 mm (5.90 in)
 20 = 200 mm (7.87 in)
 25 = 250 mm (9.84 in)
 30 = 300 mm (11.81 in)
 35 = 350 mm (13.78 in)
 40 = 400 mm (15.75 in)
 45 = 450 mm (17.72 in)
 50 = 500 mm (19.69 in)
 55 = 550 mm (21.65 in)
 60 = 600 mm (23.62 in)

4. Rear / front adapter hole position ⁽¹⁾

MO = both adapters at 0° (standard position)
 MF = both adapters at 90°

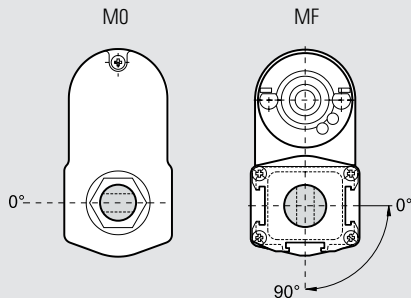

5. Options

N = no option
 NPO = potentiometer feedback
 NHW = manual override ⁽¹⁾

Dimensions for manual override option

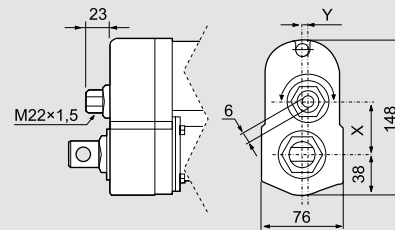

Model	X	Y
DAxx05A(B)65-	49.6	0.0
DAxx10A(B)65-	43.3	5.2
DAxx20(21)A(B)65-	38.9	0.0

6. Connector option

-A = AMP terminal 42098-2, house 180908-5
 -B = Packard Electric 56 Series
 -D = no connector (flying leads)

7. Front adapter option

E = cross hole for 0.5 inch pin
 K = cross hole for 10 mm pin
 M = cross hole for 12 mm pin

8. Rear adapter option

E = cross hole for 0.5 inch pin
 K = cross hole for 10 mm pin
 M = cross hole for 12 mm pin

(1) Only adapter position MO possible with option manual override.

Electrak[®] LA14 – Electrical Connections

Without Option

Actuator supply voltage	[Vdc]	
DA12		12
DA24		24
DA36		36

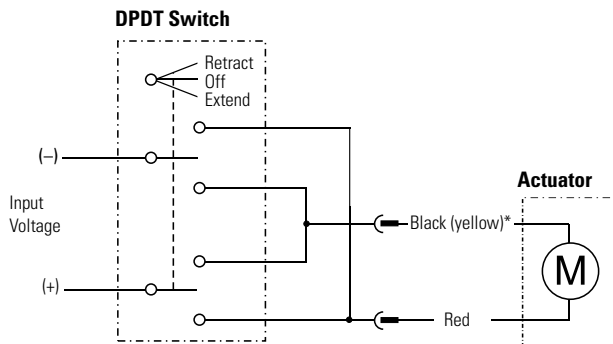

* Lead can be black or yellow

Connect the red lead to positive and black (yellow)* to negative to extend the actuator. Change polarity to retract the actuator.

Option Potentiometer

Actuator supply voltage	[Vdc]	
DA12		12
DA24		24
DA36		36
Potentiometer type		wire-wound
Potentiometer max. input voltage	[Vdc]	32
Potentiometer max. power	[W]	2
Potentiometer linearity	[%]	± 0.25
Potentiometer output resolution	[ohm/mm]	
50 - 255 mm stroke		39
256 - 510 mm stroke		20
511 - 600 mm stroke		10

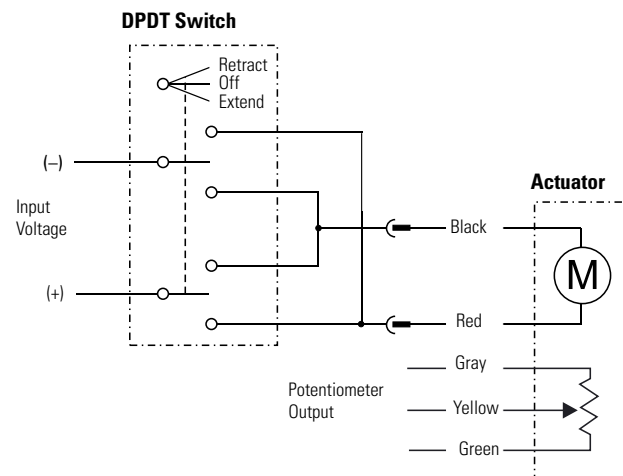

Connect the red lead to positive and black to negative to extend the actuator. Change polarity to retract the actuator. The potentiometer output cable has 0 ohm between gray and yellow leads when the actuator is fully extended.



Electrak® LA14 – Accessories

Mounting Pin Kits

Designation	A [mm (in)]	Part Number
Mounting pins (pair)	12 (0.47)	D603 023

The mounting pins are used in the rear and front adapter holes of the actuator. The pins have a groove in each end so that it can be secured with snap rings.

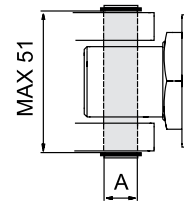

Dimensions
mm

Mating Connectors

Designation	Part Number
North American mating connector kit (connector option -B in the ordering key)	9100-448-001
Rest of the world mating connector kit (connector option -A in the ordering key)	LA100B9P1

The mating connector kit consist of the necessary connector parts required to be able to connect to the connector on the actuator wires.

Magnetic Sensor

Designation	Contact Type	Part Number
Magnetic sensor	normally open	D535 070
Magnetic sensor	normally closed	D535 071
Magnetic sensor	changing	D535 073

Specifications

Parameter	D535 070 D535 071	D535 073
Maximum power [W]	10	10
Maximum voltage [Vdc]	100	100
Maximum current [A]	0,5	0,5
Maximum contact resistance [ohm]	20	20
Lead cross section [mm ²]	2 × 0,14	3 × 0,14
Cable length [mm]	3000	3000
Protection class	IP67	IP67

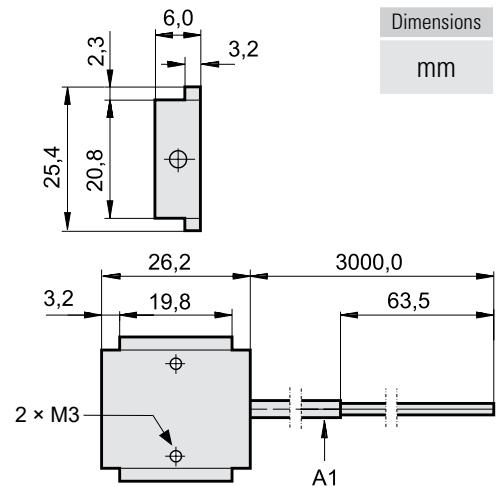

Dimensions
mm

A1: cable

The magnetic sensor fits in to the T-slot running along three sides of the cover tube. The cable is moulded into the sensor.

Electrak® LA14 – Accessories

Mounting Pin Bracket Kits

Designation	Part Number
Mounting pin brackets (pair)	D603 029

The mounting pin brackets are used to attach the front and rear adapter via a pair of mounting pins to the objects to which it is mounted. Note! one pair of brackets is needed per adapter as there must be a bracket on each side of the adapter.

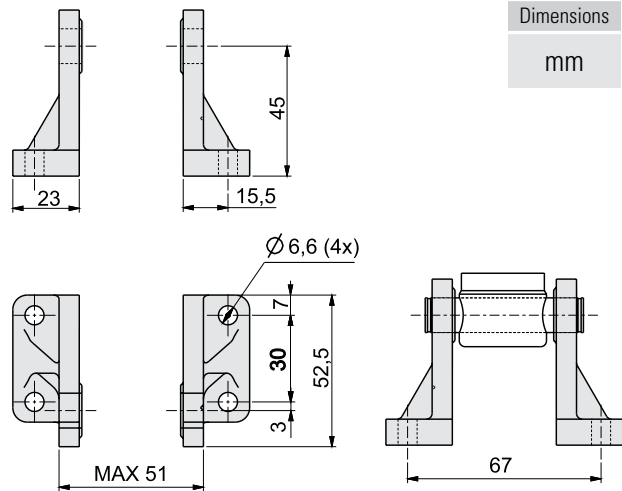

Dimensions
mm

Trunnion Mounting Kits

Designation	Part Number
Trunnions (pair)	D603 022
Trunnion brackets (pair)	D603 030

The trunnions can be mounted to the T-slot running along the right and left side of the cover tube.

Trunnions

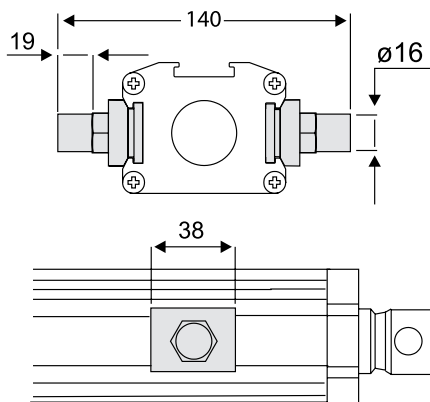

Dimensions
mm

Trunnion Brackets

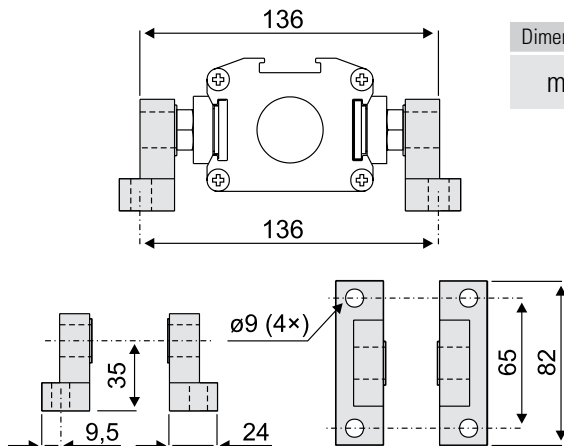

Dimensions
mm